

PRECISION SENSORS

ProFinder™ 7000+ PROFESSIONAL STUD FINDER

IMPORTANT: READ BEFORE USING. SAVE THESE INSTRUCTIONS.

Operating/Safety Instructions

PRECISION SENSORS PROFINDER 7000+

Congratulations on selecting a Precision Sensors stud finder – the most advanced wall sensing technology on the market. Your ProFinder 7000+ incorporates advanced technology that precisely senses the surface in 13 locations simultaneously, then instantly identifies the location(s) of hidden object(s). It is quick, easy and accurate.

SAFETY RULES FOR THE PROFINDER 7000+

WARNING: Read all instructions before use. Failure to follow safety instructions may result in electric shock, fire, and/or serious injury and death.

SAVE THESE INSTRUCTIONS

WARNING: It is possible that there may be wood, metal, wiring, or other objects behind the surface that are not detected. The stud finder may also detect pipes, wires, or other objects that the user may not want it to detect. The stud finder is designed to detect any inconsistency but does not identify what type of inconsistency or object it detects. The illuminated LEDs may indicate the location of many different features including, but not limited to, studs, beams, water pipes, gas pipes, wires, an inconsistency in the surface material or paint, etc.

WARNING: TURN OFF all gas, water, and electric power before using any drilling or penetrating devices or equipment including drills, saws, routers, hammers, nails, screws, etc.

WARNING: The stud finder alone should not be relied upon exclusively to locate objects behind a scanned surface. Use other sources of information to help locate objects. Other sources of information may include, but are not limited to, construction plans, visible points of entry of pipes, location of switches and outlets, and standard stud spacing practices.

FAILURE TO TAKE THESE AND OTHER NECESSARY PRECAUTIONS COULD RESULT IN ELECTRIC SHOCK, FIRE, AND/OR SERIOUS INJURY AND DEATH.

Clean

Before turning on, ensure that the stud finder is clean and dry. If necessary, wipe the stud finder dry using a clean cloth. If the detector is wet or dirty it may not operate properly.

Temperature

If the stud finder is subject to a significant temperature change, allow it to adjust to the ambient temperature before using. The entire area of the sensor board should be at a similar temperature for best operation.

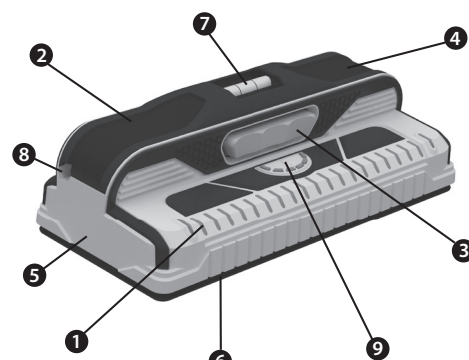

1. LED Lights
2. Ergonomic Handle
3. "On" Button
4. Battery Cover
5. Detector Housing
6. Sensor Board
7. Bubble Level
8. Pencil Caddy
9. Live Wire Meter

OPERATING INSTRUCTIONS

TO OPERATE:

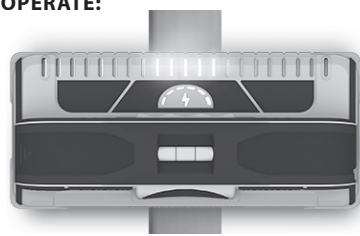

- Hold the stud finder by the handle. Do not touch the detector outside of the handle area while scanning.

- Place the ProFinder 7000+ firmly against the surface. Press and hold the "on" button.

- With the button depressed, you may immediately begin scanning the wall. (No calibration or tuning is required.) As you scan, LED lights will immediately display the location of any hidden objects.

- The "on" button may be pressed before or after placing the stud finder on the surface to be scanned. The stud finder will operate if slid across the wall, but no sliding is required.

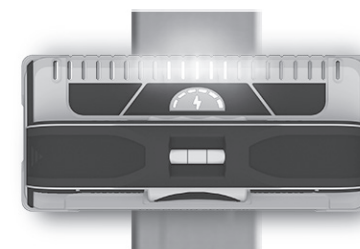

- LED lights indicate the width of hidden object(s).

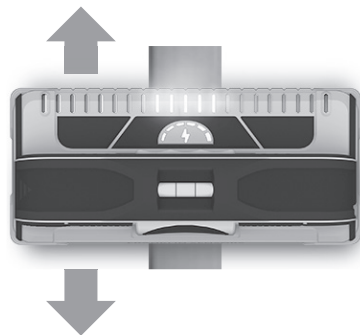

- On some surfaces it may be helpful to slide the stud finder up and down to confirm the location of a stud.

Handle Hold

When operating the ProFinder 7000+ the hand should remain on the handle. Holding the 7000+ on the sides may cause the unit to work inaccurately.

CONVENIENT PENCIL CADDY

The ProSensor 7000+ has a convenient pencil caddy. The pencil can be removed easily by gently pressing on the opening with your thumb or finger and sliding the pencil out.

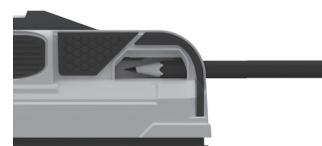

LIVE WIRE METER

The ProSensor 7000+ Live Electrical Warning™ works continually while the button is depressed. When a live electrical wire is detected, the yellow LEDs on the Live Wire Meter, patent pending, will illuminate in sequence as the electrical strength increases.



Live wires are most commonly found in two configurations.

- 1) The wire runs vertically next to the stud, or
- 2) A hole is drilled through the stud and the wire is threaded through the stud.

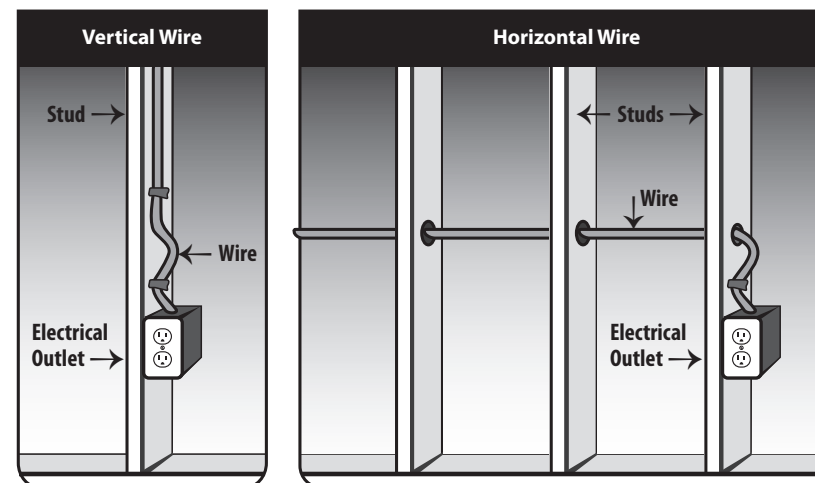

- For vertically running wires, scan the stud finder side to side.
- For horizontally running wires, run the stud finder up and down the stud.
- In both cases, the Live Wire Meter will increase in strength as you approach the live wire.

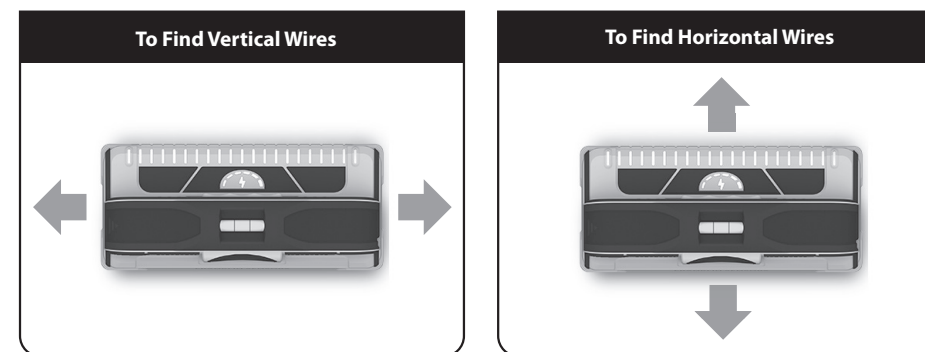

The ProSensor 7000+ uses Active Learning Technology™. To best detect the presence of live electrical wires, slowly scan in both directions, passing over the same location multiple times, for a more accurate reading.

NOTE: The ProSensor 7000+ Live Electrical Warning™ is optimized for finding live wires on or near studs.

WARNING: This product may not detect all live wires or all hidden objects. Always turn off the electrical power, gas and water supplies before penetrating a surface.

SENSING THROUGH DIFFERENT MATERIALS:

Moisture

The scanned surface should be clean and dry. Paint and wallpaper need to be completely dry before scanning for studs. It may take up to 2 weeks for wallpaper to dry enough to detect studs.

Foil-Backed Insulation

Although not common, foil-backed insulation can cause inconsistent readings with all electronic stud finders, including the ProFinder 7000+.

Metallic Content in Wallpaper

Wallpaper with metallic content can block the detector's signals.

Textured Walls and Acoustic Ceilings

The ProFinder 7000+ is capable of detecting studs through many textures and surfaces. The unit will however work most accurately if placed firmly against the flattest portions of the wall. For the best results, prior to beginning your scan, identify a horizontal area that is consistently the flattest.

Lath and Plaster

Irregularities in plaster thickness and variations in construction materials can make it difficult to locate studs behind lath and plaster walls. Also, the stud finder may not be able to detect if the plaster uses metal mesh reinforcement. Although many users have success, there is no guarantee the ProFinder 7000+ will work on all lath and plaster walls.

Tile, Flooring, Roofing, and Exteriors

The ProFinder 7000+ works by measuring the density of material behind the sensors to determine the location of studs. Due to the variability of density in tile flooring, roofing and exterior materials, we do not recommend the ProFinder 7000+ for use in these applications.

STICKERS / DECALS

Do not place decals or stickers, especially those containing metal, on the sensor board, or on the stud finder in any place.

DISASSEMBLY / TEFLON PADS

Do not disassemble the stud finder or remove the teflon pads on the bottom. The stud finder will not operate correctly without the teflon pads properly in place.

BATTERIES

The ProFinder 7000+ uses 2 AA batteries. Do not mix old and new batteries. Do not mix alkaline, standard or rechargeable batteries.

Use 1.5 volt alkaline batteries only.

REPLACING THE BATTERIES

- Remove the battery cover by sliding the cover to the right and lifting. Remove both batteries and dispose of them properly. Please recycle.

- Replace with new AA batteries.

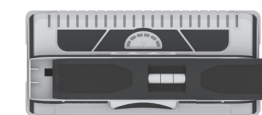

- Replace battery cover. Close battery cover by sliding the cover to the left until it snaps into place.

DISPOSAL

Stud finders and packaging should be sorted for recycling.

ENVIRONMENTAL CONDITIONS

Precision Sensors stud finders will work best when maintained in the following environmental conditions:

Storage Temperature	(0°F to 120°F) (-18°C to 50°C)
Humidity	0% to 90% Relative humidity (non-condensing)
Operating Temperature	(32°F to 110°F) (0°C to 43°C)
Humidity	0% to 90% Relative humidity (non-condensing)

FCC PART 15 CLASS B REGISTRATION WARNING

This device complies with Part 15 of FCC rules. Operation is subject to the following two conditions:

1. This device may not cause harmful interference, and
2. This device must accept any interference received, including interference that may cause undesired operation.

LIMITED WARRANTY

Precision Sensors warrants this product to be free from defects in material and workmanship for one year. This LIMITED WARRANTY does not cover products that are improperly used, abused, or altered. Defective products will be replaced or repaired. If a product is found to be defective within the warranty period, Precision Sensors will, at its sole discretion, either repair or replace the defective product. This limited warranty does not apply to products that are subjected to freight damage, accident, abuse, alteration, misuse, improper repair, etc. Precision Sensors and Precision Sensors' authorized distributors shall bear no other liability or obligation under this warranty.

IN NO EVENT SHALL PRECISION SENSORS HAVE ANY LIABILITY FOR CONSEQUENTIAL OR INCIDENTAL DAMAGES INCLUDING, BUT NOT LIMITED TO, LOST PROFITS, DAMAGE TO GOODWILL, LOSS OF TIME, INCONVENIENCE OR OTHER COMMERCIAL OR ECONOMIC LOSS, and in no event shall Precision Sensors be liable for damages exceeding the purchase price.

In the event of a product defect, please return the product postage paid with proof of purchase to:

Precision Sensors Inc.
Attn: Returns Department
6700 N Linder Rd
Suite #156-159
Meridian, ID 83646
(208) 830-8111
returns@franklinsensors.com
Hours of Operation: Monday-Friday,
8 AM to 5 PM,
Mountain Time Zone

US Patents 8,476,912 8,593,163 8,669,772
8,736,283 8,791,708 8,836,347 8,884,633
US and Foreign Patents Pending.

PS7000+E0 (6/21)

TROUBLESHOOTING

CONDITION	PROBABLE CAUSE	SOLUTION
No LED lights come on.	Weak battery.	Replace with 2 new AA alkaline batteries. Do not mix old and new batteries.
Stud finder only works momentarily.	The "on" button isn't being held down.	Hold the "on" button down until you have completed your scan.
The LED lights are indicating the location of pipes and wires, not just studs.	The ProFinder 7000+ indicates the location of inconsistencies. The LED lights may indicate the location of a pipe, electrical wiring, other objects near the surface being scanned, or an inconsistency in the surface material or paint, etc.	Look for evenly placed studs on either side (40.6 cm/16 inches, 60.9 cm/24 inches, on center, etc.) Scan above the location and below the location to confirm results. Use caution before penetrating wall. See the SAFETY RULES FOR THE PROFINDER 7000+.
Difficulty starting a scan near doors and windows.	Solid headers and triple studs are often present around doors and windows. The ProFinder 7000+ indicates the change in density. If all the sensors sense the same density, the LEDs will not illuminate.	Begin the scan away from the window or door, then move the stud finder to the area around the window or door. For best results, keep stud finder 3"/7cm away from wood trim, outlets, switches, etc.
Stud finder doesn't work through new wall paper.	The moisture in the wall after wall papering can block the stud finder's signal.	Wait until the wallpaper is dry. It may take up to 2 weeks for the paper to dry sufficiently.
My house was built prior to about 1960. The walls are lath and plaster. The stud finder doesn't work very well anywhere in my house.	Older houses that were built with lath and plaster, instead of sheet rock, often have too much inconsistency in the walls for the detector to work reliably.	Try using the stud finder at a higher point on the wall, or a lower point on the wall.
Inconsistent readings.	Operator is holding the unit near the base rather than on the handle.	Only hold the unit by the handle with a finger continually pressing the button.
	Anomaly in the surface material.	Test at a higher or lower location on the wall.
	Sometimes after continuously scanning the wall for a period of time the readings seem to be less consistent.	Release the button and press the button again.
The LED lights sometimes seem to light up sporadically or inconsistently.	Wires, pipes, or other construction inconsistencies can cause erratic or erroneous readings. Features on the opposite side of a wall may also be a source of inconsistent readings.	Test at points on the wall that are higher, or lower. The stud finder may also work best if it is used more than 3"/7cm away from metal objects such as outlets, light switches, etc.